

FULL-PNEUMATIC WHEEL ASSEMBLIES (PN)

Capacities to 675 lbs.

Standard Features

- 3-Piece Demountable Wheels
- Tube Type
- Zerk Fitting On Hub
- Ball or Roller Bearing

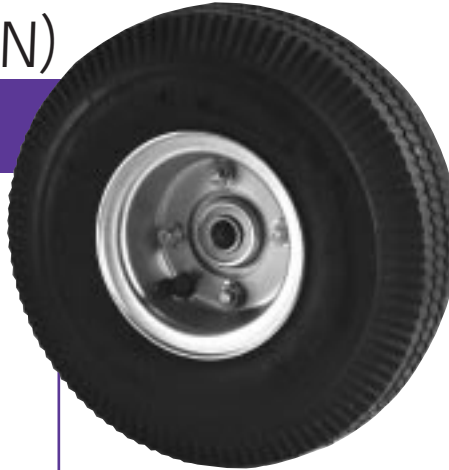

APPLICATIONS:

- Hand Trucks
- Dollies
- Replacement Wheels for Pneumatic Casters (page ?)
- Pneumatic Assemblies Offer Smoothest Ride Over Rough Terrain

Optional Features

- Polyurethane Foam Fill (Suffix-PF)
- Gray Non-Marking Tire 8" & 10" (Suffix-G)
- Many Other Tire & Wheel Combinations Available

Size Inches	Hub	Hub Length Inches	Ply	Bearing Type	Bearing Size Inches	Capacity Lbs.	Weight Lbs.	Notes	Part Number
8 (280/250 x 4)	Centered	3 1/2	4	Ball	3/4	295	4.0	Replacement Wheel for Caster #S183B-PN	8PN-B
	Centered	3 1/4	4	Roller	3/4	295	4.2	Replacement Wheel for Caster #S183R-PN & S683R-PN	8PN-R
10 (410/350 x 4)	Offset	2 1/4	2	Ball	5/8	260	5.0	Standard Replacement for Hand Truck	10PN
	Centered	3 1/2"	2	Ball	3/4	260	5.1	Replacement Wheel for Caster #S1103B-PN	10PN-B
	Centered	3 1/2"		Roller	3/4	410	5.4	Replacement Wheel for Caster #S1103R-PN & S6103R-PN	10PN-R
12 (410/350 x 6)	Centered	4 1/4	2	Ball	3/4	295	6.0	Replacement Wheel for Caster #S1123B-PN	12PN-B
	Centered	4 1/4	4	Rib	3/4	675	6.3	Replacement Wheel for Caster #S1123R-PN & S6123R-PN	12PN-R

Ball bearings standard. Available in 1/2", 5/8", and 3/4"

*Specify hub length and bearing size.

SEMI-PNEUMATIC WHEELS (SN)

Capacities to 600 lbs.

APPLICATIONS:

- Hand Trucks
- Dollies
- Other Sizes Available
- 8 x 2.50, 10 x 2.75, 12 x 3.0 Sizes have injection molded cores for impact resistance. All others have pressed steel cores.

Size Inches	Hub	Hub Length Inches	Tread	Capacity Lbs.	Weight Lbs.	Part Number
5 x 1.25*	Offset	1 3/8	Rib	30	.6	SN-512
6 x 1.50*	Centered	1 3/8	Rib	50	.7	SN-613
	Offset	1 1/2	Rib	50	.7	SN-616
7 x 1.50*	Offset	1 3/8	Diamond	55	.8	SN-712
	Centered	1 3/4	Rib	55	.8	SN-715
8 x 1.75*	Offset	1 3/8	Diamond	60	.9	SN-812
	Centered	1 3/4	Rib	60	.9	SN-816
8 x 2.50**	Offset	2 1/4	Rib	275	2.0	SN-825
10 x 2.75**	Offset	2 1/4	Rib	300	3.5	SN-105
12 x 3.0**	Centered	3 1/4	Rib	600	6.0	SN-123

Ball bearings standard.

*1/2" Bore Ball Bearing **5/8" or 3/4" Bore Ball Bearing



SANTOPRENE® (SP)

Capacities to 700 lbs.

Standard Features

- **Composition** - Non marking grey tread on polyolefin core
- **Tread And Hub** - Double bonded and mechanically interlocked
- **Resistant To Chemicals, Caustics, And Mild Acids**
- **Temperature Range Of -40° to 230°F**
- **Nylon Sealed Washers** - On all roller bearing wheels

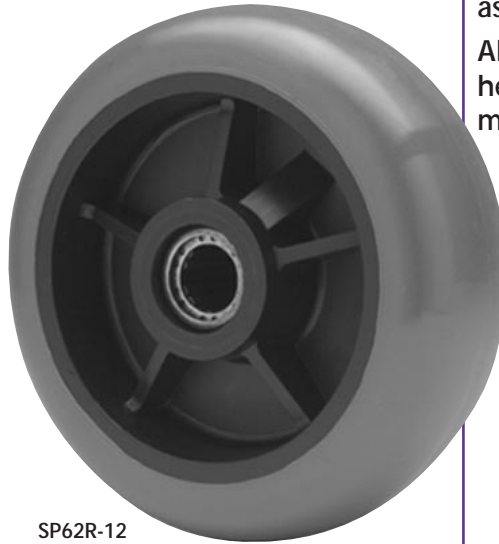

SP62R-12



SP5B-06

APPLICATIONS:
Light to light medium duty institutional environments such as schools, hospitals, etc.
Also suitable for medium heavy applications where non marking tread is required.



SP510P-05

Dia. Inches (mm)	Face Inches (mm)	Hub Length Inches (mm)	Load Capacity lbs (KGS)	Wt. lbs. (KGS)	Ball Bearing		Roller Bearing		Delrin Bearing	
					Part No.	Sizes	Part No.	Sizes	Part No.	Sizes
2 1/2 (60)	1 ³ / ₈ (21)	1 1/64 (26)	100 (45)	.25 (.10)	—	—	—	—	SP2510P-04	1/4
	1 3/8 (35)	1 9/16 (40)	140 (63)	.25 (.10)	SP25B-06	5/16, 3/8, 1/2	—	—	SP25D-06	3/8, 1/2
3 (76)	1 ³ / ₈ (21)	1 5/32 (29)	90 (40)	.2 (.20)	—	—	—	—	SP310P-04	1/4
	1 3/8 (35)	1 9/16 (40)	170 (77)	.5 (.20)	SP3B-06	3/8, 1/2	—	—	SP3D-06	3/8, 1/2
3 1/2 (89)	1 3/8 (35)	1 9/16 (40)	180 (81)	.3 (.14)	SP35B-06	3/8, 1/2	—	—	SP35D-06	3/8, 1/2
4 (102)	1 ⁵ / ₁₆ (24)	1 5/32 (29)	115 (52)	.25 (.10)	—	—	—	—	SP410P-05	5/16
	1 3/8 (35)	1 9/16 (40)	200 (90)	.3 (.14)	SP4B-06	3/8, 1/2	—	—	SP4D-05	3/8, 1/2
	2 (50)	2 3/16 (56)	350 (158)	1.2 (.54)	—	—	SP42R-12	1/2, 5/8, 3/4	SP42D-12	1/2, 5/8, 3/4
5 (127)	1 ⁵ / ₁₆ (24)	1 5/32 (29)	125 (56)	.3 (.30)	—	—	—	—	SP510P-05	5/16
	1 3/8 (35)	1 9/16 (40)	225 (101)	1.0 (.45)	SP5B-06	3/8, 1/2	—	—	SP5D-06	3/8, 1/2
	2 (50)	2 9/16 (56)	450 (203)	1.6 (.72)	—	—	SP52R-12	1/2, 5/8, 3/4	SP52D-12	1/2, 5/8, 3/4
6 (152)	1 3/8 (35)	1 9/16 (40)	250 (112)	1.2 (.54)	SP6B-06	3/8, 1/2	—	—	SP6D-06	3/8, 1/2
	2 (50)	2 3/16 (56)	550 (248)	1.7 (.76)	—	—	SP62R-12	1/2, 5/8, 3/4	SP62D-12	1/2, 5/8, 3/4
8 (203)	2 (50)	2 3/16 (56)	700 (315)	2.5 (1.1)	—	—	SP82R-12	1/2, 5/8, 3/4	SP82D-12	1/2, 5/8, 3/4

Note: 1³/₁₆ " and 1⁵/₁₆ " wide wheels are plain bore.

Note: Standard bearing size is called out in last two digits of part number in sixteenths (ie. SP62R-12 = 3/4" bearing, SP62R-10 = 5/8" bearing).
For smaller bore refer to spanner bushings in component parts selection (page 102).