

# SANTOPRENE® (SP)

Capacities to 700 lbs.

## Standard Features

- **Composition** - Non marking grey tread on polyolefin core
- **Tread And Hub** - Double bonded and mechanically interlocked
- **Resistant To Chemicals, Caustics, And Mild Acids**
- **Temperature Range Of -40° to 230°F**
- **Nylon Sealed Washers** - On all roller bearing wheels

## APPLICATIONS:

Light to light medium duty institutional environments such as schools, hospitals, etc.

Also suitable for medium heavy applications where non marking tread is required.

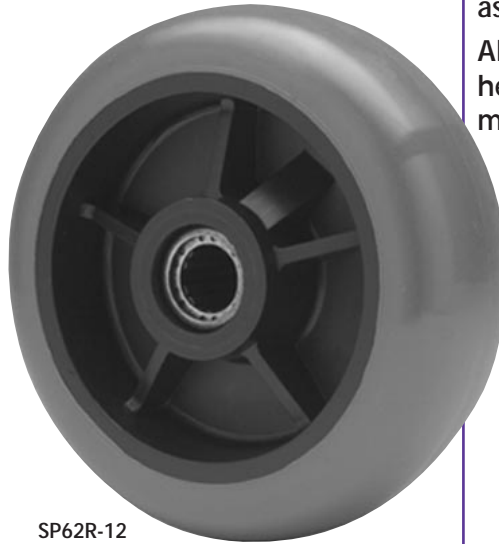

SP62R-12



SP5B-06



SP510P-05

Dia. Inches (mm)	Face Inches (mm)	Hub Length Inches (mm)	Load Capacity lbs (KGS)	Wt. lbs. (KGS)	Ball Bearing		Roller Bearing		Delrin Bearing	
					Part No.	Sizes	Part No.	Sizes	Part No.	Sizes
<b>2 1/2</b> (60)	1 3/16 (21)	1 1/64 (26)	100 (45)	.25 (.10)	—	—	—	—	SP2510P-04	1/4
	1 3/8 (35)	1 9/16 (40)	140 (63)	.25 (.10)	SP25B-06	5/16, 3/8, 1/2	—	—	SP25D-06	3/8, 1/2
<b>3</b> (76)	1 3/16 (21)	1 5/32 (29)	90 (40)	.2 (.20)	—	—	—	—	SP310P-04	1/4
	1 3/8 (35)	1 9/16 (40)	170 (77)	.5 (.20)	SP3B-06	3/8, 1/2	—	—	SP3D-06	3/8, 1/2
<b>3 1/2</b> (89)	1 3/8 (35)	1 9/16 (40)	180 (81)	.3 (.14)	SP35B-06	3/8, 1/2	—	—	SP35D-06	3/8, 1/2
<b>4</b> (102)	1 5/16 (24)	1 5/32 (29)	115 (52)	.25 (.10)	—	—	—	—	SP410P-05	5/16
	1 3/8 (35)	1 9/16 (40)	200 (90)	.3 (.14)	SP4B-06	3/8, 1/2	—	—	SP4D-05	3/8, 1/2
	2 (50)	2 3/16 (56)	350 (158)	1.2 (.54)	—	—	SP42R-12	1/2, 5/8, 3/4	SP42D-12	1/2, 5/8, 3/4
<b>5</b> (127)	1 5/16 (24)	1 5/32 (29)	125 (56)	.3 (.30)	—	—	—	—	SP510P-05	5/16
	1 3/8 (35)	1 9/16 (40)	225 (101)	1.0 (.45)	SP5B-06	3/8, 1/2	—	—	SP5D-06	3/8, 1/2
	2 (50)	2 9/16 (56)	450 (203)	1.6 (.72)	—	—	SP52R-12	1/2, 5/8, 3/4	SP52D-12	1/2, 5/8, 3/4
<b>6</b> (152)	1 3/8 (35)	1 9/16 (40)	250 (112)	1.2 (.54)	SP6B-06	3/8, 1/2	—	—	SP6D-06	3/8, 1/2
	2 (50)	2 3/16 (56)	550 (248)	1.7 (.76)	—	—	SP62R-12	1/2, 5/8, 3/4	SP62D-12	1/2, 5/8, 3/4
<b>8</b> (203)	2 (50)	2 3/16 (56)	700 (315)	2.5 (1.1)	—	—	SP82R-12	1/2, 5/8, 3/4	SP82D-12	1/2, 5/8, 3/4

Note: 1 3/16 " and 1 5/16 " wide wheels are plain bore.

Note: Standard bearing size is called out in last two digits of part number in sixteenths (ie. SP62R-12 = 3/4" bearing, SP62R-10 = 5/8" bearing).  
For smaller bore refer to spanner bushings in component parts selection (page 102).

# SOFT RUBBER (SR)

Capacities to 240 lbs.

## Standard Features

- **Composition** - Rubber wheel, hard core, soft tread
- **Good Floor Protection** - Quiet movement and cushioned ride
- **Temperature Range Of** - 40° to 158°F

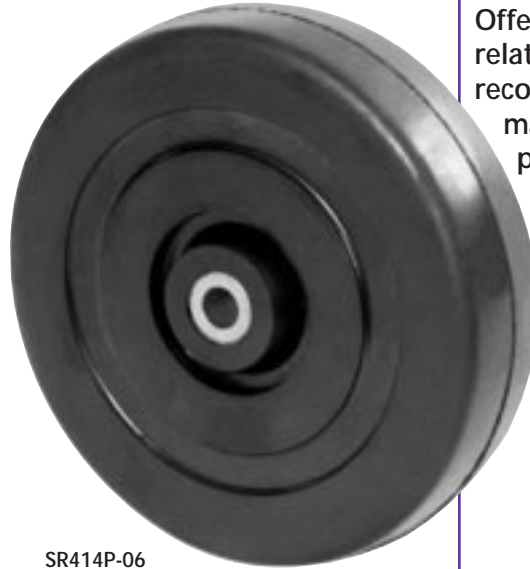

SR414P-06

## APPLICATIONS:

Most popular in light, general, and light medium duty series.

Offers quiet mobility at relatively low cost. Not recommended where loads may sit static for long periods as permanent flat spotting may occur.

Dia. Inches (mm)	Face Inches (mm)	Hub Length Inches (mm)	Load Capacity lbs. (KGS)	Wt. lbs. (KGS)	Plain Bore or Bore Less Roller Bearings		Roller Bearing		Ball Bearings	
					Part No.	Sizes	Part No.	Sizes	Part No.	Sizes
1 5/8 (41)	47/64 (18)	3/4 (19)	70 (31)	.05 (.14)	SR158P-04 •	1/4	—	—	—	—
2 (50)	7/8 (22)	15/16 (24)	80 (36)	.07 (.14)	SR278P-04 •	1/4	—	—	—	—
	1 (25)	1 1/64 (26)	90 (40)	.1 (.16)	SR210P-04 •	1/4	—	—	—	—
2 1/2 (63)	1 1/8 (28)	1 3/8 (35)	100 (45)	.2 (.2)	SR25P-05 •	5/16	—	—	—	—
3 (76)	13/16 (21)	1 1/64 (26)	90 (40)	.2 (.54)	SR310P-04 •	1/4	—	—	—	—
	1 1/4 (32)	1 9/16 (40)	175 (79)	.25 (.45)	SR314P-06 •	3/8	SR314R-08	1/2	SR314B-06	3/8
3 1/2 (89)	1 5/16 (33)	1 9/16 (40)	200 (90)	.4 (.72)	SR35P-06 •	3/8	—	—	SR35B-06	3/8
4 (102)	15/16 (24)	1 5/32 (29)	115 (52)	.25 (.76)	SR410P-05 •	5/16	—	—	—	—
	1 1/4 (32)	1 9/16 (40)	200 (90)	.4 (1.1)	SR414P-06 •	3/8	SR414R-08	1/2	SR414B-06	3/8
	1 5/8 (41)	1 15/16 (49)	240 (108)	.6 (.14)	SR415P-07*	7/16	SR415R-10	5/8	—	—
5 (127)	15/16 (33)	1 5/32 (29)	125 (56)	.3 (.54)	SR510P-05 •	5/16	—	—	—	—
	1 1/4 (32)	1 9/16 (40)	200 (90)	1.7 (.45)	SR514P-06 •	3/8	SR514R-08	1/2	SR514B-06	3/8

• Supplied with celcon bushing designed to run directly on axle.

\* Supplied with oil impregnated sintered iron bushing designed to run directly on axle.

# HARD RUBBER (HR)

Capacities to 600 lbs.

## Standard Features

- Composition - Hard rubber molded throughout
- Good Load Rating, Good Floor Protection
- Temperature Range of -40° to 158°F

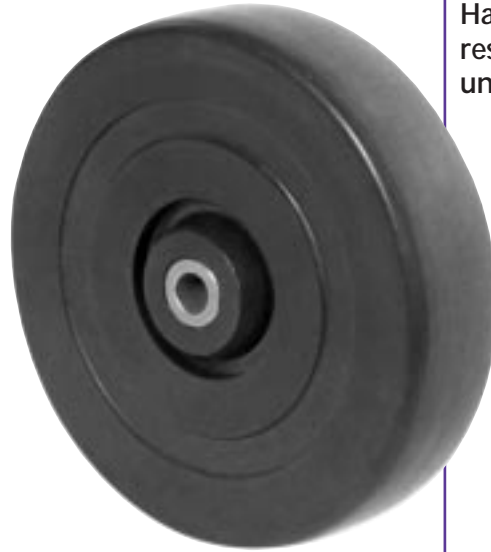

HR514P-06

## APPLICATIONS:

Popular in general and light medium duty series.

Hard wheel offers low rolling resistance. Will not flat spot under static load.

Dia. Inches (mm)	Face Inches (mm)	Hub Length Inches (mm)	Load Capacity lbs. (KGS)	Wt. lbs. (KGS)	Plain Bore or Bore Less Roller Bearing		Roller Bearing		Ball Bearing	
					Part No.	Sizes	Part No.	Sizes	Part No.	Sizes
<b>2</b> (50)	1 (25)	1 1/64 (26)	150 (67)	.07 (.03)	HR20P-04 •	1/4	—	—	—	—
<b>2 1/2</b> (63)	1 1/8 (28)	1 3/8 (35)	200 (90)	.2 (.09)	HR25P-05 •	5/16	—	—	—	—
<b>3</b> (76)	13/16 (21)	1 1/64 (26)	100 (95)	.2 (.09)	HR310P-04 •	1/4	—	—	—	—
	1 1/4 (32)	1 9/16 (40)	270 (122)	.25 (.11)	HR314P-06 •	3/8	HR314R-08	1/2	HR314B-06	3/8
<b>3 1/2</b> (89)	1 5/16 (33)	1 9/16 (40)	275 (124)	.4 (.18)	HR3514P-06 •	3/8	—	—	—	—
<b>4</b> (102)	15/16 (24)	1 5/32 (29)	125 (56)	.25 (.11)	HR410P-05 •	5/16	—	—	—	—
	1 1/4 (32)	1 9/16 (40)	275 (124)	.4 (.18)	HR414P-06 •	3/8	HR414R-08	1/2	HR414B-06	3/8
	1 5/8 (41)	1 15/16 (49)	420 (189)	.6 (.27)	HR415P-07*	7/16	HR415R-10	5/8	—	—
<b>5</b> (127)	15/16 (24)	1 5/32 (29)	135 (61)	.35 (.16)	HR510P-05 •	5/16	—	—	—	—
	1 1/4 (32)	1 9/16 (40)	300 (135)	1.0 (.45)	HR514P-06 •	3/8	HR514R-08	1/2	HR514B-06	3/8

• Supplied with celcon bushing designed to run directly on axle.

\* Supplied with oil impregnated sintered iron bushing designed to run directly on axle.